

# SKID LOADER

## Mod. 755



SKID LOADERS



# SKID LOADER 755

**WEIGHT**  
Kg. 2.500

**OPERATING WEIGHT**  
Kg.612

**ENGINE POWER**  
Kw 36,5

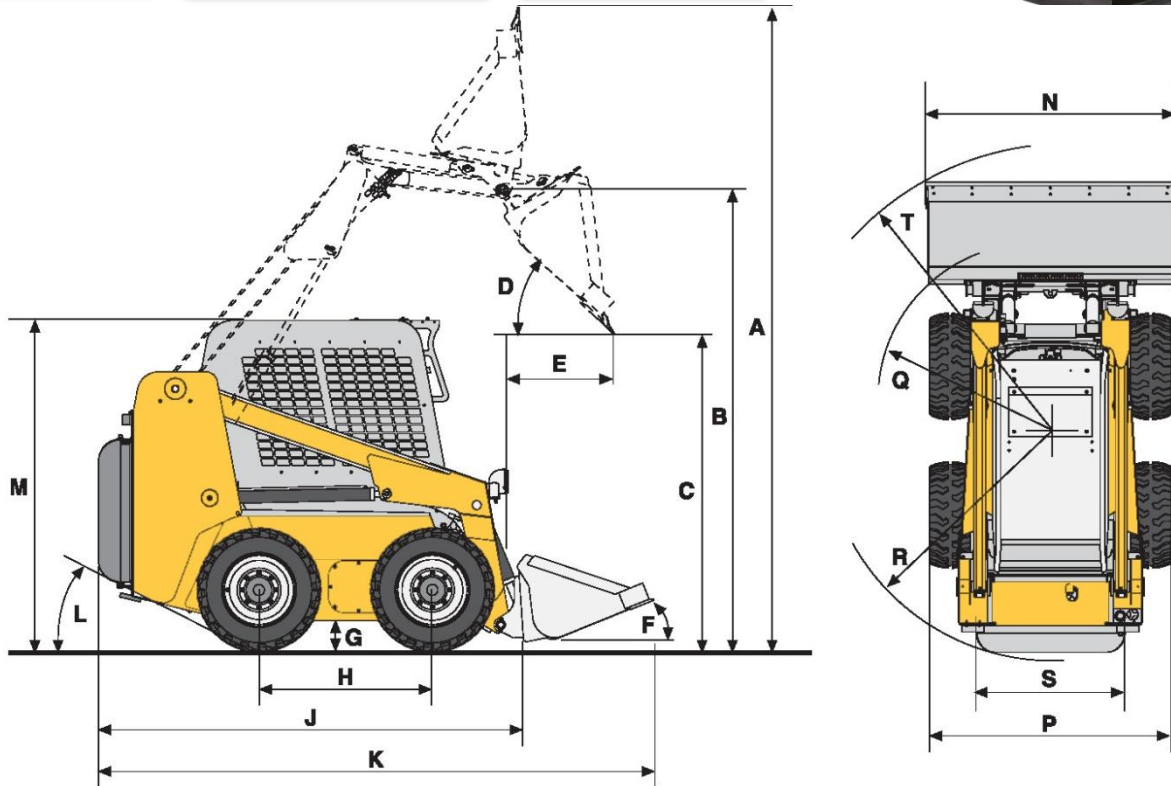

## DIMENSIONS

| Dimension                             | Unit | Value |
|---------------------------------------|------|-------|
| A – Maximum operating height          | mm   | 3.745 |
| B – Bucket pin height                 | mm   | 2.870 |
| C – Dump height                       | mm   | 2.250 |
| D – Dump angle                        | °    | 36    |
| E – Dump clearance at max height      | mm   | 610   |
| F – Bucket closure angle              | °    | 29    |
| G – Minimum height from ground        | mm   | 193   |
| H – Wheelbase                         | mm   | 933   |
| J – Total length without bucket       | mm   | 2.547 |
| K – Total length with standard bucket | mm   | 3.239 |
| L – Rear starting angle               | °    | 25,2  |
| M – Maximum machine height            | mm   | 1.979 |
| N – Max. width with standard bucket   | mm   | 1.574 |
| P – Max width without standard bucket | mm   | 1.511 |
| Q – Front diameter                    | mm   | 1.161 |
| R – Rear diameter                     | mm   | 1.530 |
| S – Track tread width                 | mm   | 1.245 |
| T – Front diameter                    | mm   | 1.880 |

## Technical specifications

|                               |           |                |
|-------------------------------|-----------|----------------|
| Operating weight              | Kg        | 2.500          |
| Operating capacity            | Kg        | 612            |
| Tipping load                  | Kg        | 1.224          |
| Speed                         | Km/h      | 0-11           |
| Fuel tank capacity oil/diesel | l         | 38/66          |
| Engine                        |           | KUBOTA         |
| Displacement                  | cc        | 2.434          |
| Net power / rpm               | Kw        | 36,5 / 2700    |
| Hydrostatic drive pumps       | bar l/min | 345 2x113      |
| Gear pump                     | bar l/min | 180 70         |
| Cooling system                |           | Heat exchanger |
| Tires                         |           | 10-16,5        |

## CAMS MACCHINE S.P.A.

Strada S. Michele, 37 Cailungo B5 BORGO MAGGIORE R.S.M.

Tel. +378.0549.988111 Fax +378.0549.903793

[www.camsgroup.com](http://www.camsgroup.com) info@camsgroup.com

