

SKID LOADER

Mod. 635



SKID LOADERS



SKID LOADER

Mod. 635

WEIGHT

Kg. 2.000

OPERATING WEIGHT

Kg.550

ENGINE POWER

Kw 25,7

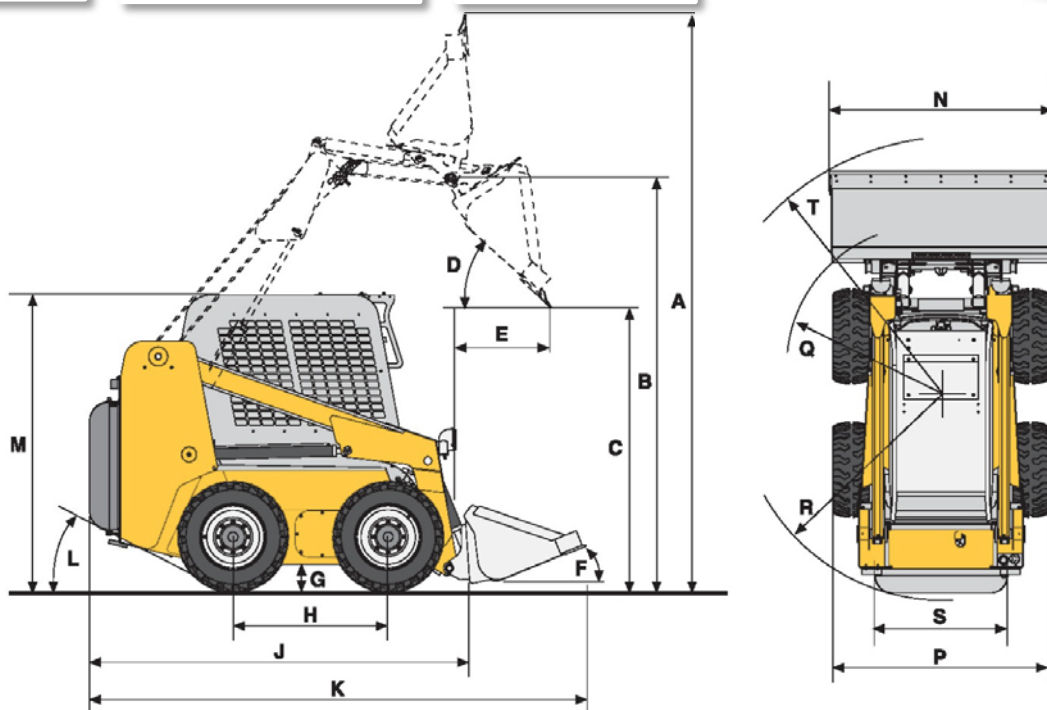

DIMENSIONS

A – Maximum operating height	mm	3.450
B – Bucket pin height	mm	2.630
C – Dump height	mm	1.950
D – Dump angle	°	40.5
E – Dump clearance at max height	mm	670
F – Bucket closure angle	°	24.8
G – Minimum height from ground	mm	168
H – Wheelbase	mm	810
J – Total length without bucket	mm	2.230
K – Total length with standard bucket	mm	2.910
L – Rear starting angle	°	28.4
M – Maximum machine height	mm	1.850
N – Max. width with standard bucket	mm	1.270
P – Max width without standard bucket	mm	1.220
Q – Front diameter	mm	1.060
R – Rear diameter	mm	1.320
S – Track tread width	mm	1.000
T – Front diameter	mm	1.734

Technical specifications

Operating weight	Kg	2.000
Operating capacity	Kg	550
Tipping load	Kg	1.100
Speed	Km/h	0-10,5
Fuel tank capacity oil/diesel	l	25/28
Engine		KUBOTA
Displacement	cc	1.647
Net power / rpm	Kw	25,7 / 2800
Hydrostatic drive pumps	bar l/min	300 2x78
Gear pump	bar l/min	180 56
Cooling system		Heat exchanger
Tires		27x8,5-15

CAMS MACCHINE S.P.A.

Strada S. Michele, 37 Cailungo B5 BORGO MAGGIORE R.S.M.

Tel. +378.0549.988111 Fax +378.0549.903793

www.camsgroup.com info@camsgroup.com

